

TYPICAL SUBDIVISION REUSE CONNECTION

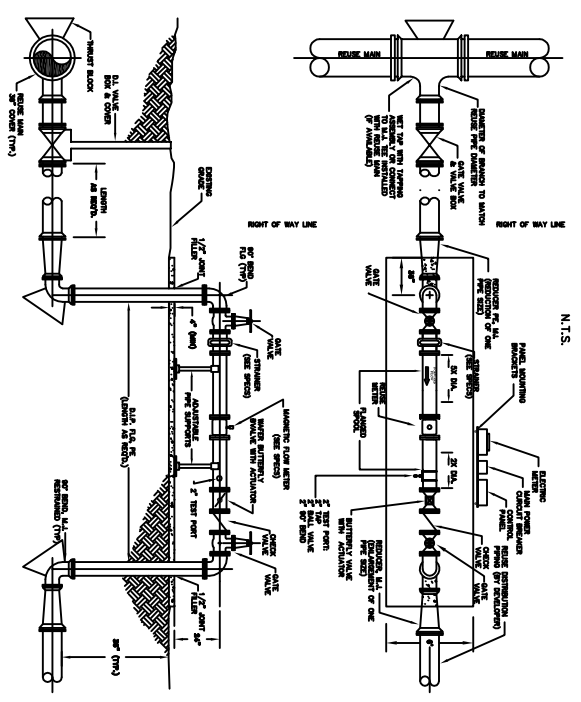

- NOTES:
1. METER AND CONTROL ASSEMBLY SHALL BE INSTALLED WITHIN THE RIGHT-OF-WAY OF THE DEVELOPMENT OR WITHIN THE RIGHT-OF-WAY OF THE DEVELOPMENT OR WITHIN A UTILITY EASEMENT THAT MAY BE ACQUIRED BY THE CITY OF LAKE WALES.
  2. ADDITIONAL PRING AND/OR APPOINTMENTS MAY BE REQUIRED TO EXAMINE COMPONENTS WITH OTHER DEVELOPMENTS. THE DEVELOPERS REUSE DISTRIBUTION SHALL BE INSTALLED WITHIN THE REUSE MAIN WITH THE DEVELOPERS REUSE PRING.
  3. (4'-6" DIA.) 1 COAT 75-COLOR ENAMEL-SHED (2-5 FT). COLOR: PANTONE PURPLE

REUSE WATER MAIN CONTROL ASSEMBLY

REUSE WATER CONNECTION DETAILS

REUSE WATER AIR RELEASE VALVE (END VIEW)

REUSE WATER AIR RELEASE VALVE (SIDE VIEW)

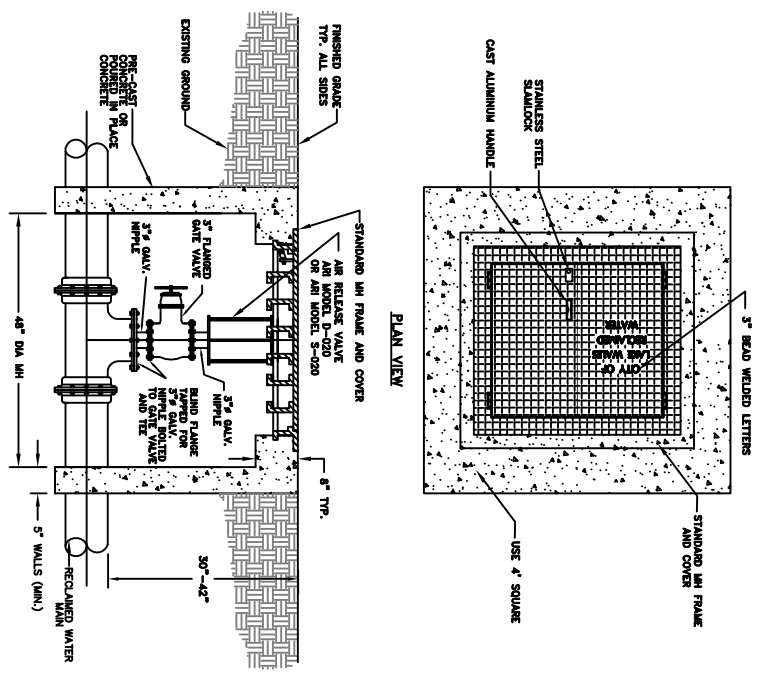

- NOTE:
1. USE TAPPING SADDLE FOR 4" DIA AND SMALLER RECLAIMED WATER MAIN AND TEE WITH BLIND FLANGE FOR 6" DIA AND LARGER RECLAIMED WATER MAIN.

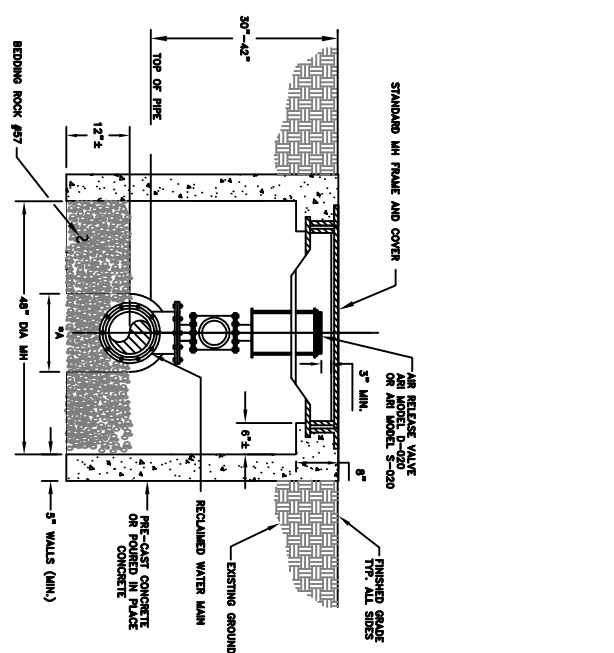

- NOTES:
1. USE TAPPING SADDLE FOR 4" DIA AND SMALLER RECLAIMED WATER MAIN AND TEE WITH BLIND FLANGE FOR 6" DIA AND LARGER RECLAIMED WATER MAIN.

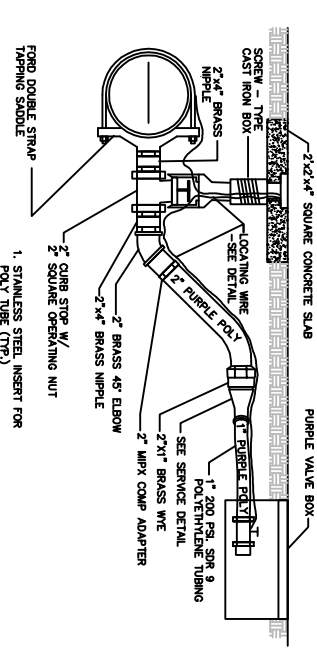
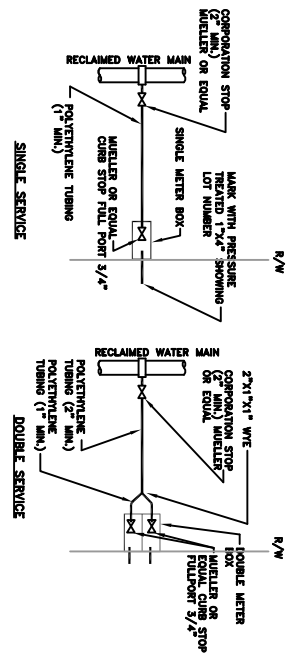

- NOTES:
1. ALL FITTINGS SHALL BE BRASS WITH COMPRESSION/PACK JOINT CONNECTIONS.
  2. NO SERVICE LINE SHALL CONNECT OR TERMINATE UNDER A DRIVEWAY.
  3. EACH SERVICE SHALL TERMINATE IN A METER BOX ASSEMBLY, WHICH SHALL BE PLACED TO GRADE IN THE RIGHT-OF-WAY AT THE PROPERTY LINE(S) OF THE LOT(S) TO BE SERVED WITH CURB STOP.
  4. THE CONTRACTOR SHALL BE RESPONSIBLE FOR SETTING LETTER BOX TO FINISH GRADE AND MARKING GRADE ADJUSTMENT TO METER BOX IF REMOVAL OCCURS. CITY OF LAKE WALES SHALL TURNISH AND SET LETTER.
  5. PANTONE PURPLE 2527 WITH LIGHT STRIKE OF COLORANT.

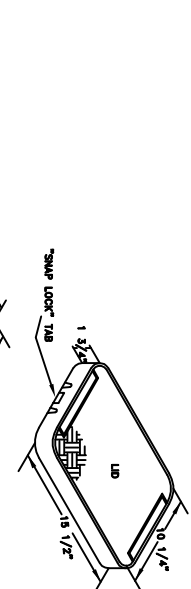

RHINO - METER BOXES  
MB16 - PURPLE COMPLETE - TR HOLE  
MB18 - PURPLE COMPLETE - TR HOLE

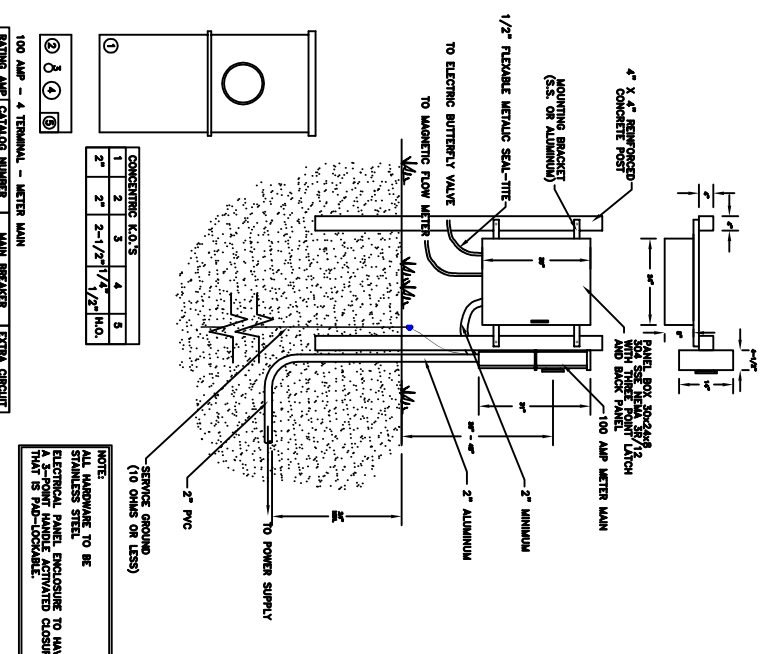
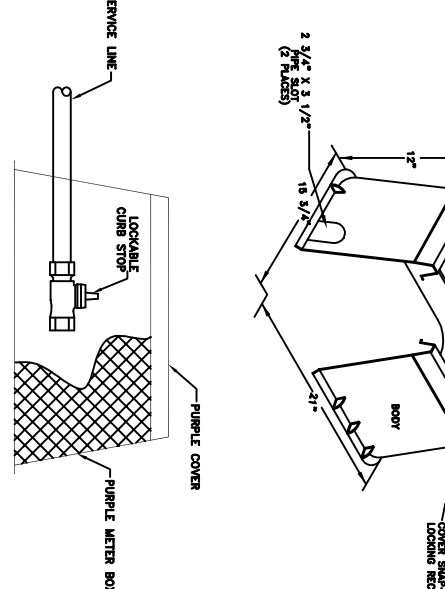

- NOTE:
- CONCRETE TO BE STAINLESS STEEL ELECTRICAL PANEL ENCLOSURE TO HAVE A 3-POUNT HANDLE ACTIVATED CLOSING HUNT IS TAB-COORDABLE.

100 AMP - 4 TERMINAL - METER MAIN	100 AMP	4 BRANCH
RATING AMP	100 AMP	4 BRANCH
TERMINAL TYPE	100 AMP	4 BRANCH
TERMINAL TYPE	100 AMP	4 BRANCH

1	2	3	4	5
2"	2"	2-1/2"	1/4"	N.O.

1	2	3	4	5
2"	2"	2-1/2"	1/4"	N.O.

1	2	3	4	5
2"	2"	2-1/2"	1/4"	N.O.

1	2	3	4	5
2"	2"	2-1/2"	1/4"	N.O.

1	2	3	4	5
2"	2"	2-1/2"	1/4"	N.O.

1	2	3	4	5
2"	2"	2-1/2"	1/4"	N.O.

1	2	3	4	5
2"	2"	2-1/2"	1/4"	N.O.

1	2	3	4	5
2"	2"	2-1/2"	1/4"	N.O.



CITY OF LAKE WALES  
201 CENTRAL AVE  
863-678-4182

REV.	DESCRIPTION

ISSUE CODE	A PRELIMINARY	B DESIGN
DESIGN BY:	D CONSTRUCTION	E APPROVAL
CHK'D BY:	DATE:	ENGR.
DRAWING TITLE	REUSE DETAILS	
JOB NO.		

ISSUE CODE	
SHEET	1 OF 2
REV.	

REUSE MAIN CONTROL ASSEMBLY ELECTRICAL DETAIL

STANDARD RECTANGULAR METER BOX ASSEMBLY